



HotJetusa[®]
1.800.624.8186

**3030 DIESEL
COLD WATER
JETTER**
HOT WATER OPTION AVAILABLE



SHOWN WITH 600 GALLON UPGRADE

MODEL NUMBERS:

XFDTA3030Y (TANDEM AXLE COLD WATER)

HJDTA3030Y (TANDEM AXLE HOT WATER)

CULVERT / STORM DRAIN CLEANER

- **30GPM @ 3,000 PSI**
- **72HP YANMAR (John Deere) TURBO DIESEL ENGINE**
- **7K TANDEM AXLE TRAILER / 14K UPGRADE AVAILABLE**
- **330 GALLON CAPACITY / 600 GALLON UPGRADE**

BUILT WITH THE OPERATOR IN MIND!

- **Engineered to Clean from 4" to 36" Pipes**
- **Built for Easy Operation, Service & Long Life**



BEST ENGINE

Premium Yanmar (John Deere) Turbo • Water Cooled

BEST PUMP

BEST TRAILER

Solid Steel Diamond Plate • Solid Box Frame

INDUSTRIALLY ENGINEERED FOR YEARS OF SERVICE

INCLUDES

- **Tool Boxes**
- **Wash Down / Power Wash Feature**
- **Anti-Freeze System**
- **Strobe Light**
- **Fast Fill System**
- **Remote Control (Loaded Model)**
- **Safety Shut-Off**

72 HP ENGINE

WATER COOLED

TURBO DIESEL POWERED

NOW EVEN MORE RELIABLE

The YANMAR line of Final Tier 4 engines continues to build upon the legendary reliability of the YANMAR TNV line with a focus on vibration reduction and high-strength materials. The result is an engine more than capable of handling the most demanding applications.

FINAL TIER 4 AND EU STAGE 5 COMPLIANT

Building off the proven TNV design, YANMAR has achieved superior exhaust emissions utilizing common rail direct-injection, exhaust gas recirculation, precise ECU engine control and a diesel particulate filter. YANMAR engines are compliant with EPA Tier 4 Final and EU Stage V regulations allowing customers to use a common platform for highly regulated sales regions.

BETTER FUEL EFFICIENCY, FEWER EMISSIONS

YANMAR continues its reputation for superior starting characteristics by refining the combustion process to assure more precise fuel delivery and control. The result is reduced emissions, improved performance over a wide range of applications and increased fuel economy.



SPECIFICATION	NVT
CYLINDERS	4
BORE x STROKE (mm)	98 x 110
DISPLACEMENT L (ci)	3.32 (203)
GROSS POWER hp (kW)	72 (53.7)
RATED SPEED rpm	2500
LENGTH w/fan in (mm)	31.3 (796)
WIDTH in (mm)	24.6 (624)
HEIGHT in (mm)	42.3 (1074)
WEIGHT lbs (kg)	~ 650 (295)

COMBUSTION TYPE	Direct Injection
ASPIRATION	Turbo Charged
GOVERNOR TYPE	Electronic
LUBRICATION SYSTEM	10.5L Capacity Oil Pan
ELECTRICAL SYSTEM	12V-80A
FUEL SYSTEM	Common Rail Fuel Injection
COOLING SYSTEM	Water Pump, Belt Driven
POWER TAKE OFF	FWH: SAE 4 FW: SAE 10

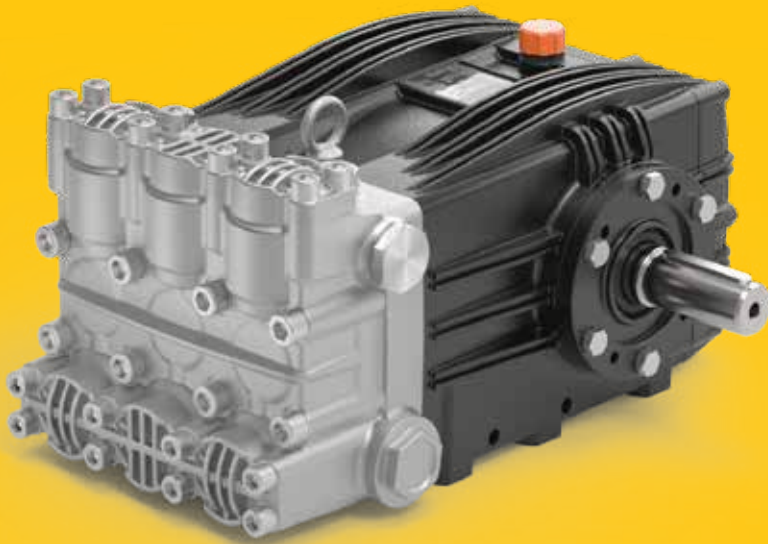

UDOR
USA

VXX SERIES

19.8-63.2 GPM
UP TO 5075 PSI

- Anodized Aluminum Crank Case
- Nickel-Plated Manifold
- Stainless Steel Check Valves
- Heavy Duty Bronze Connecting Rods
- Heavy Duty Roller Bearings
- 1-1/2" BSP-F Inlet. 1" BSP-F Outlet
- 128 oz. Oil Capacity
- Max Fluid Temp, 160°F

Ref.	Description	Ft./lb.	Nm	Loctite [®]
1	Head Bolts	103	140	-
2	Valve Caps	-	-	-
3	Inlet Cap	147	200	-
4	Outlet Cap	133	180	243
5	Bearing Flange Bolts	30	57	-
6	Rear Cover Bolts	8	11	-
7	Connecting Rod Bolts	19	25	243
8	Plunger Bolts	30	40	243
9	Valve Cover Bolts	66	90	-
10	Oil Drain Plug	8	11	-

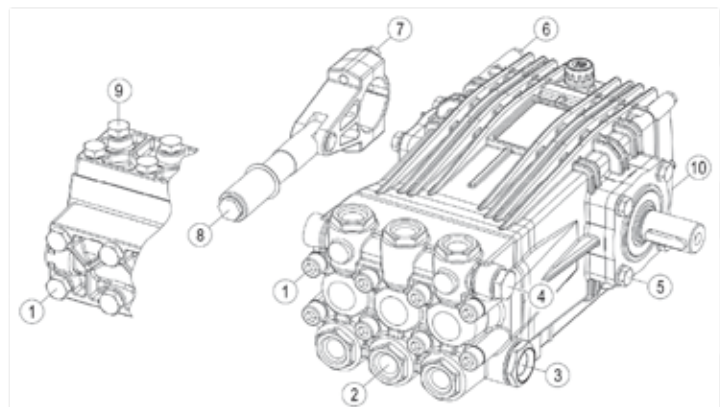





Tank Option: Twin 300 Gallon for a Total of 600 Gallons (Vertical Tanks)



Tank Option: Twin 330 Gallon for a Total of 660 Gallons (Horizontal Tanks)



THE BEST JETTERS DESERVE THE BEST TRAILERS



- » **Box Tube Steel Construction**
- » **Solid Diamond Plate Steel Deck**
- » **Fully Primed And Powder Coated**

BUILT FOR YEARS OF SERVICE



IT ALL STARTS WITH THE TRAILER



TRAILER SPECIFICATIONS

Our HotJet trailers are custom engineered for extreme duty and are the best trailers made - PERIOD!

We are associate members of **NATM - National Association of Trailer Manufacturers** and we manufacture in compliance with their national engineering codes.



FRAME

Our trailers feature a "Rock Solid" 3/16" tube fame (not 1/8") that extends the full length of the trailer. The frame is then welded on the HD C-Channel sub-frame. We directly weld this to our spring support shackles.

TOP DECK

The top deck is full sheathed diamond plate steel decking which adds structural rigidity.

AXLES

We use Dexter brand leaf spring axles. Leaf springs are proven for our applications. They cushion and distribute the weight loads. Each axle has electric brakes.

PAINT / POWDER COAT

We use a premium pre-wash zinc hot-wash. This is followed by a Sherwin Williams primer coat that is exclusively made for powder coating. A Sherwin Williams premium powder coat paint that is engineered to resist corrosion and promote color consistency is then added.

MISCELLANEOUS

We use HD fenders with step plates welded on both sides. The Ram Jack is super duty and rated to lift 8,000 lbs. All lights and markers are LED. Plug is standard 7-way.



CHOOSE YOUR TRAILER COLOR!



Red, Black & Blue Standard Color Options
Custom Paint Colors Available Upon Request - Cost Extra



CUSTOM SIGNAGE AVAILABLE



ARTWORK REQUIREMENTS:

Custom signage is designed by our in-house graphic artist. Provide your logo/ branding in high resolution VECTOR FORMAT (.ai, .eps or vector PDF) and we'll do the rest! A proof will be provided for review prior to print production.

THE BEST JETTERS INCLUDE THE BEST TRAINING CLASSES

