

QUALITY • VALUE • PERFORMANCE

HOTJET II® DIESEL SERIES

PRODUCT BRIEF

04-07-2026

MODEL NUMBERS:

HJ2-K-1240-SA-200GL

HJ2-K-1240-SA-330GL

HJ2-K-1240-TA-330GL



12GPM @ 4,000 PSI

24.8HP Kubota Diesel Engine

Full Hydraulic Hose Reel

Equipped with either 300' 3/8" or 300' 1/2" or 500' of 3/8", our full hydraulic hose reels feature a roller guide arm that helps preserve the longevity of the reel.

Pump

The pump systems we use are manufactured by Industrial Division of Giant Pumps. These Premium Tri-Plex Pumps are proven with literally thousands in service worldwide. They are easy and inexpensive for service.

Pump Saver System / EZ Start Valve

We engineer all jetter trailers with our "pump saver system" - that when the hose flow is released, the bypass water re-circulates back to the water tank. This keeps the head of the pump cool extending its life substantially.

TBDS™ (Total Belt Driven System)

All components are belt driven. The pump is Triple-V-Belt Driven. Belt driven reduces vibration and allows the pump to run at 1/2 RPM. This extends operational life, especially vs. gear driven power plants.

Detergent Application / Injection

The equipment operator can control the concentration levels at the machine and controls the detergent injections depending on the job needs.

Quick Antifreeze System / Recycle System

Our jetter units come with our quick antifreeze system where you close one ball valve and open the antifreeze ball valve - then run the machine for 30 seconds and the entire system is antifreezed. Start the machine - then recapture the antifreeze in the antifreeze tank and re-attach the jetter nozzle and you are ready to jet!

Cleans 2" to 12" Lines

KUBOTA DIESEL 24.8HP ENGINE

MODEL		D1305-E48
EMISSION REGULATION		Tier 4
TYPE		Vertical 4-cycle Liquid Cooled Diesel
NUMBER OF CYLINDERS		3
BORE	MM (IN)	78.0 (3.07)
STROKE	MM (IN)	88.0 (3.46)
DISPLACEMENT	L (CU. IN)	1.261 (76.95)
COMBUSTION SYSTEM		IDI
INTAKE SYSTEM		Naturally Aspirated
MAXIMUM SPEED	RPM	2600
OUTPUT: GROSS INTERMITTENT	kW	18.5
	HP	24.8
	PS	25.2
DIRECTION OF ROTATION		Counterclockwise Viewed on Flywheel
OIL PAN CAPACITY	L (GAL)	5.7 (1.51)
STARTER CAPACITY	V-KW	12-1.2
ALTERNATOR CAPACITY	V-A	12-40
LENGTH	MM (IN)	503.5 (19.82)
WIDTH	MM (IN)	374.4 (14.74)
HEIGHT (1)	MM (IN)	590.1 (23.20)
HEIGHT (2)	MM (IN)	215.6 (8.49)
DRY WEIGHT	KG (LB)	95.0 (209.4)

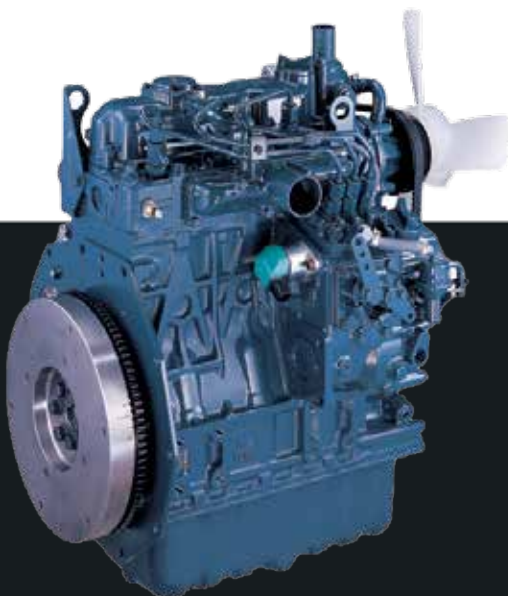
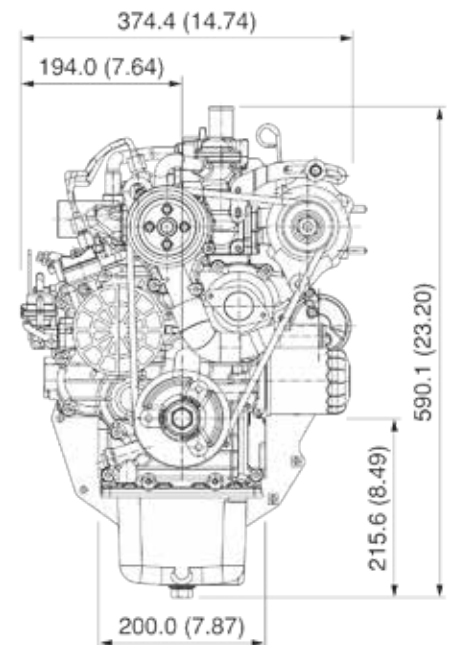
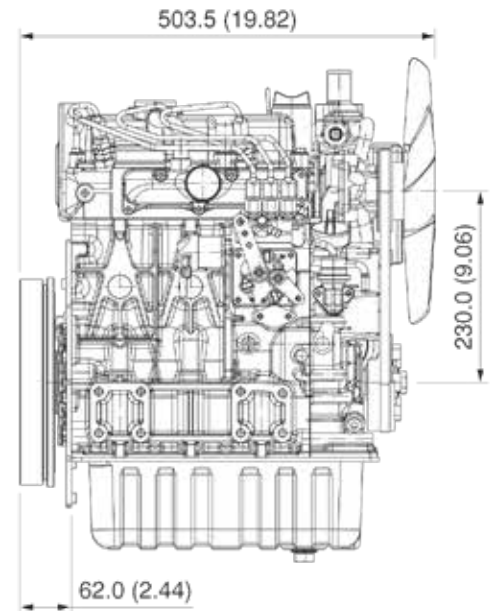

The D1305 engine complies with EPA Tier 4 emissions regulations which is the most stringent emissions regulations in the world in this class.

Kubota engine less than 19kW meets emission standards over the NRTC and also meets the NTE requirements.

GIANT PUMP P400HP SERIES

Operation and Maintenance

Check oil level prior to starting to ensure trouble-free water supply.

Important!

If there is a danger of frost, the water in the pump and in the pump fittings (particularly the unloader valve) must be emptied. The second discharge port can also be used and the pump run "dry" for 1-2 minutes for this purpose.

Oil amount: 30.4 ounces (0.9 liters). Only use ISO VG 220 industrial gear oil (e.g. Aral Degol BG220) or automobile gear oil SAE 90 GL4 (Giant p/n 01154).

Initial oil change after 50 operating hours and then every 500 hours, after 1 year if used less. Caution when operating in damp places or with high temperature fluctuations.

Oil must be changed immediately should condensate (frothy oil) occur in the gear box.

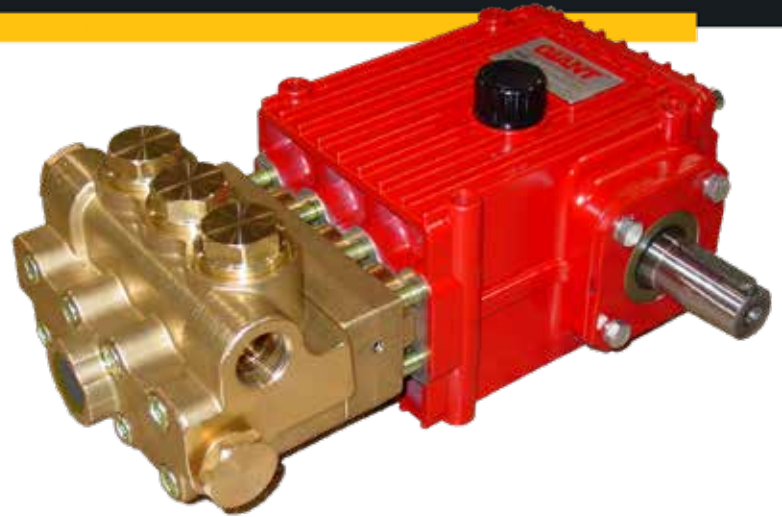

NPSH values must be observed.

Maximum input pressure 145 PSI (10 bar), maximum suction head -4.35 PSI (-0.3 bar). Make sure that suction pulsation is sufficiently dampened - water column resonance must be avoided.

Important!

If the pump is not used for a long period of time, it is possible the seals (23/23B) could become hard or brittle thus causing the pump to leak when put into operation. If this is the case, we recommend these seals be replaced every 4 years.

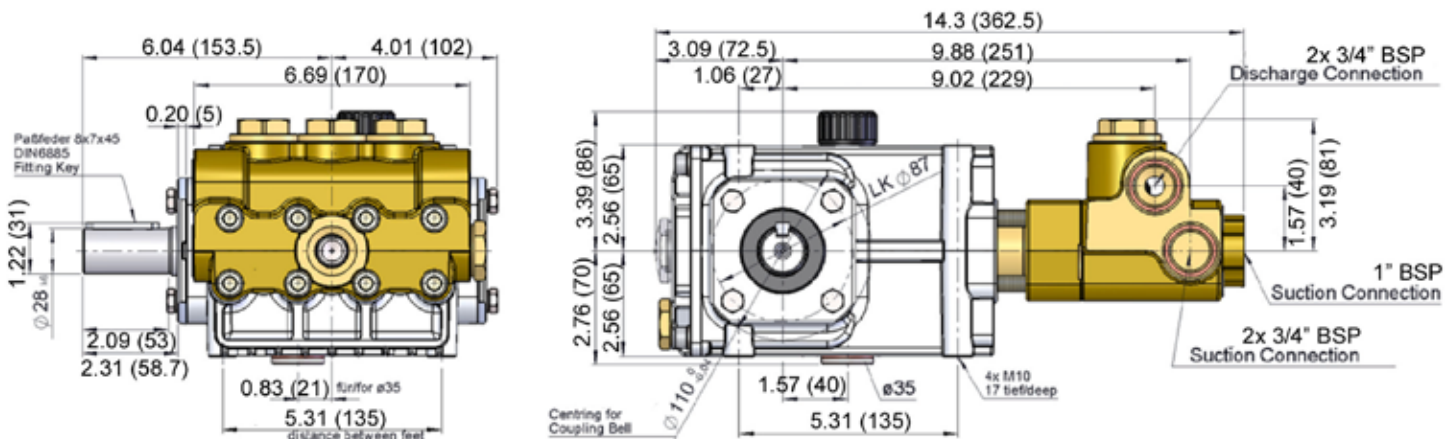

COLD WATER DIESEL SERIES SPECIFICATIONS

GENERAL SPECIFICATIONS

- 330 Gallon Water Capacity
- Molded HDP Water Tank(s)
- Nema 4 Rated Control Panel
- Low Water "Shut Off" Feature
- 10' Safety Colored Leader Hose
- 2" x 36" Tiger Tail Hose Protector
- Powered, Variable Speed Hose Reel with 300' of 3/8" Jetting Hose Rated @ 16,000 PSI Burst Pressure
- Adjustable Pressure Relief/Control Valve(s)
- Adjustable Pulsation System with Control
- Second Hose Reel with 100' of 3/4" Supply hose
- Rotary Beacon Light
- "Fast Fill" for Hydrant Hook-Up

PUMP

- "Run-Dry" Capable Tri-Plex Pump
- 12 GPM @ 4,000 PSI (+/- 5%)
- Triple Power Belt Driven
- Dual Safety Rupture Disks and Pump Saver System
- Rear Throttle Control

MOTOR DESCRIPTION

- 24.8HP Kubota
- Low Noise Muffler
- EPA Tier 4 Rated
- Low Engine Oil/High Temperature Auto Shutdown System
- 24 Gallon Diesel Fuel Tank
- Large Battery Box
- Extra Large Radiator

TRAILER DESCRIPTION

- Rugged, Compact Specially Engineered Trailer to Haul the Equipment and Water Load
- Leaf Spring Axles Cushion and Distribute the Weight for Easy Towing
- 5x12' Tandem Axle
- Tandem Axle (2x5,000 lb)
- Dual Axle Brake - DOT Legal in all 50 States
- Full Premium Powder Coat
- LED LIGHTING

NOZZLES

- Warthog (Package Dependent)
- Lazer, Ram & Spinner

INCLUDES

- Portable Reel with 100' 1/4" Jetting Hose
- Safety Cone Holder
- Rear LED Lighting
- Remote Control - Solid State Wireless Unit up to 300'
- 2nd Hose Reel for Wash Down

OVERALL DIMENSIONS

- Overall Length 16' 6" incl. hitch
- Deck Length 12'
- Height 8' w/safety light
- Overall Deck Width 7'
- Weight Dry 2,950 lbs
- Weight Full Load 6,100 lbs

UPGRADES AVAILABLE

- 14k Trailer w/600 Gallon Water Tank



Over 30 Years of Building Quality Equipment!

HOTJET D

DIESEL SERIES TRAILER MOUNTED JETTERS

www.hotjetusa.com
1-800-624-8188

HOTJETUSA®

CLEANS 2" - 12" LINES

24 Gallon Fuel Tank
Diesel

Kubota Engine
24.8HP • Large Radiator

Super Duty Tool Box
Diamond Plate / Lockable

Quiet Exhaust

Large Diesel Heater

H.D. Water Tank
330 Gallon

Safety Strobe Light

Full Rear Controls & LED Lighting

Throttle Control
Adjustable Pressure & Flow

Heavy Duty Electric Axles
Dual Axle Brakes & Chrome Wheels
10,000 lb. rated (2x 5,000lb)

Heavy Duty Hitch
Adjustable Height with 2^{5/16"} or D-Ring

Custom Tool Boxes
Large, Lockable & Weatherproof

Pulsation Valve

Premium Pump
Triple Power V-Belt Driven

Ultra Duty Trailer
Solid Diamond Plate Steel Deck Powder Coated

Trailer Colors



Manufactured by
POWER LINE USA

1-800-624-8186

14773 Heritage Crest Way Riverton, UT 84065

www.hotjetusa.com

Over 30 Years of Building Quality Equipment!



HotJetusa®

HOTJET D™

DIESEL SERIES TRAILER MOUNTED JETTERS

CLEANS 2" - 12" LINES

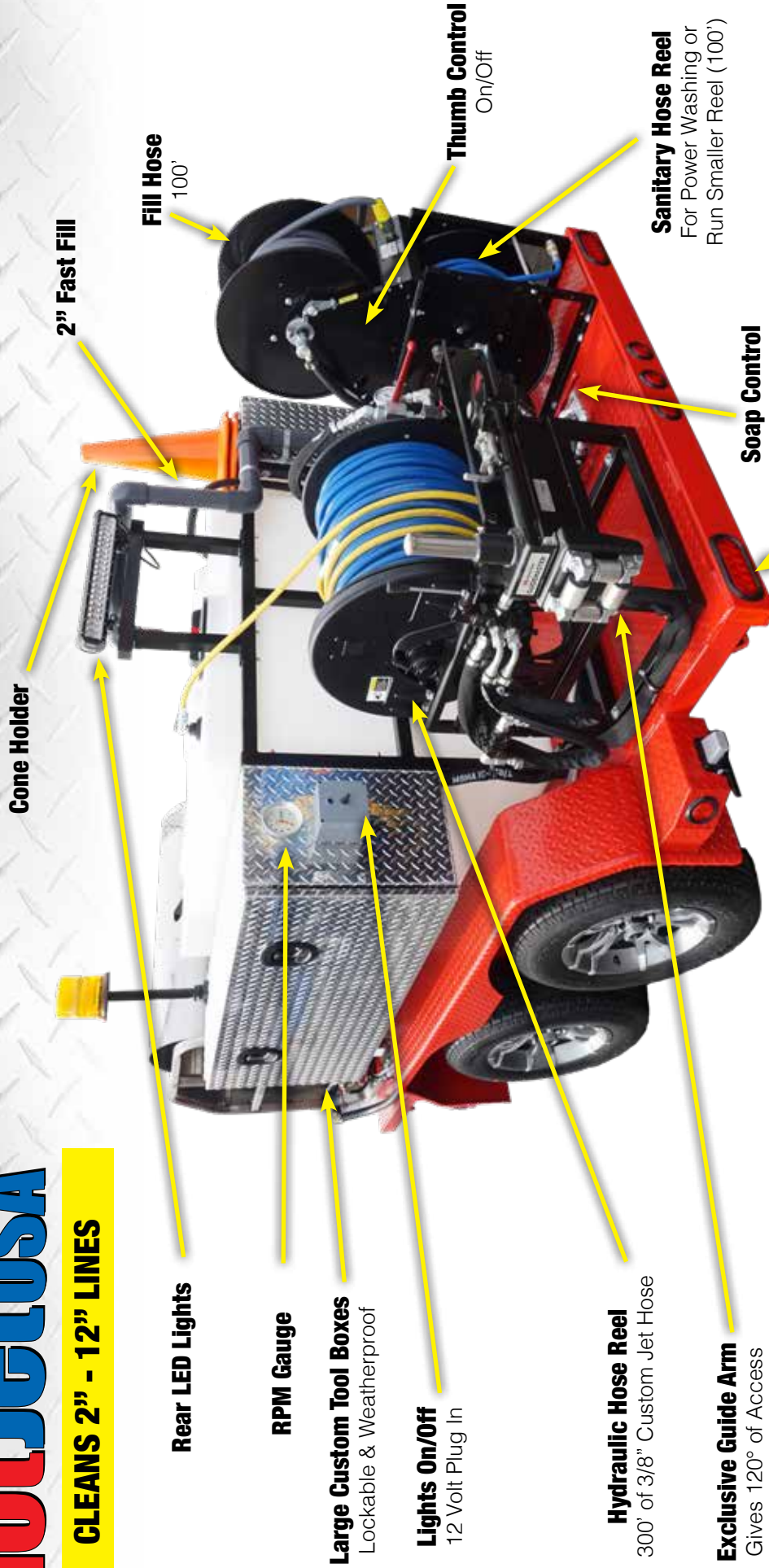

Cone Holder

2" Fast Fill

**Fill Hose
100'**

Rear LED Lights

RPM Gauge

Large Custom Tool Boxes
Lockable & Weatherproof

Lights On/Off
12 Volt Plug In

Hydraulic Hose Reel
300' of 3/8" Custom Jet Hose

Exclusive Guide Arm
Gives 120° of Access

Sanitary Hose Reel
For Power Washing or
Run Smaller Reel (100')

Soap Control

Thumb Control
On/Off

Rear LED Lights

Manufactured by
POWER LINE
USA

1-800-624-8186

14773 Heritage Crest Way Riverton, UT 84065

www.hotjetusa.com

REF 08162023



SINGLE AXLE



TANDEM AXLE



IT ALL STARTS WITH THE TRAILER



» TRAILER SPECIFICATIONS

Our HotJet trailers are custom engineered for extreme duty and are the best trailers made - PERIOD!

We are associate members of **NATM - National Association of Trailer Manufacturers** and we manufacture in compliance with their national engineering codes.



» FRAME

Our trailers feature a "Rock Solid" 3/16" tube frame (not 1/8") that extends the full length of the trailer. The frame is then welded on the HD C-Channel sub-frame. We directly weld this to our spring support shackles.

» TOP DECK

The top deck is full sheathed diamond plate steel decking which adds structural rigidity.

» AXLES

We use Dexter brand leaf spring axles. Leaf springs are proven for our applications. They cushion and distribute the weight loads. Each axle has electric brakes.

» PAINT / POWDER COAT

We use a premium pre-wash zinc hot-wash. This is followed by a Sherwin Williams primer coat that is exclusively made for powder coating. A Sherwin Williams premium powder coat paint that is engineered to resist corrosion and promote color consistency is then added.

» MISCELLANEOUS

We use HD fenders with step plates welded on both sides. The Ram Jack is super duty and rated to lift 8,000 lbs. All lights and markers are LED. Plug is standard 7-way.



THE BEST JETTERS DESERVE THE BEST TRAILERS

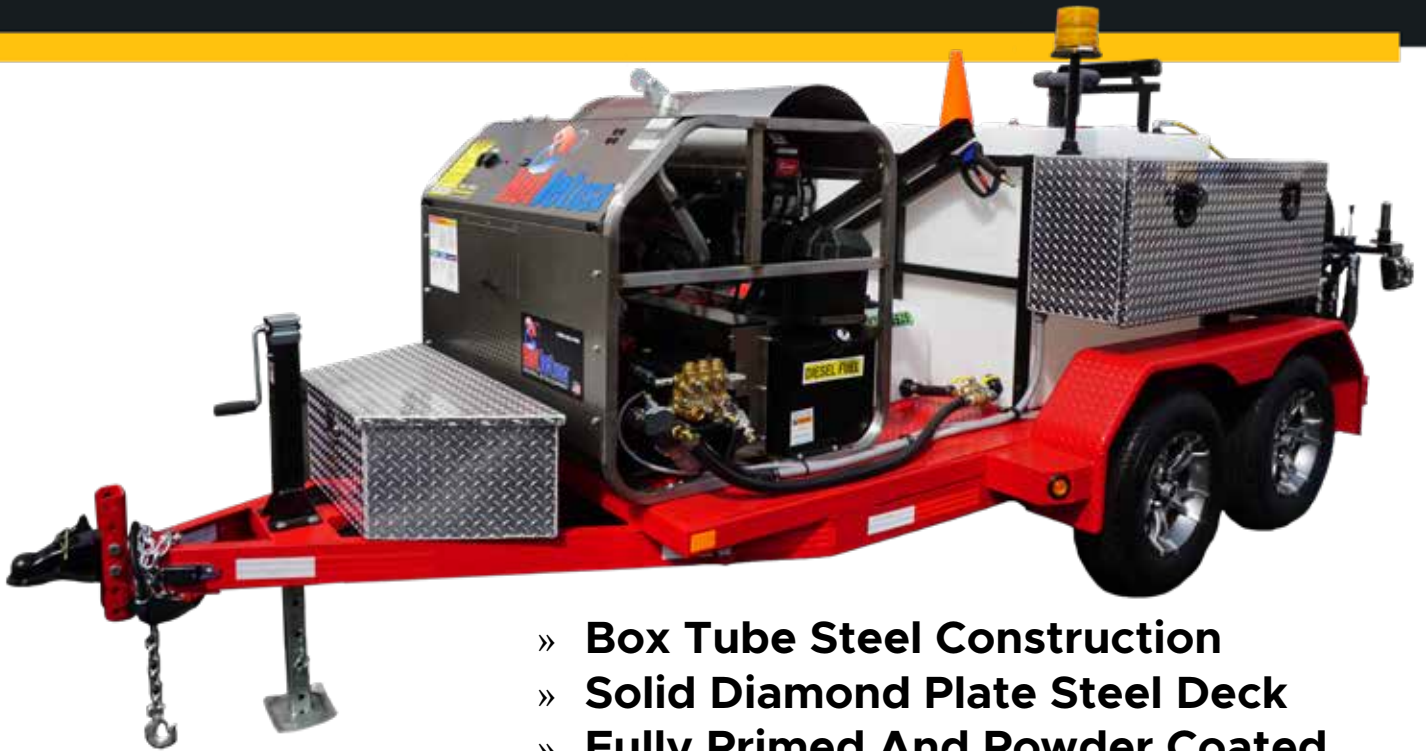

- » **Box Tube Steel Construction**
- » **Solid Diamond Plate Steel Deck**
- » **Fully Primed And Powder Coated**

BUILT FOR YEARS OF SERVICE



CHOOSE YOUR TRAILER COLOR!



Red, Black & Blue Standard Color Options
Custom Paint Colors Available Upon Request - Cost Extra



HYDRAULIC JACK OPTION AVAILABLE

The hydraulic jack package was designed to be a self-contained hydraulic trailer jack unit.

- » 3,000 PSI power unit
- » Manual override capable
- » Universal and custom brackets available



Upgrade:

7K Jack **\$1,295.00**

10K Jack **\$1,695.00**

CUSTOM SIGNAGE AVAILABLE



ARTWORK REQUIREMENTS:

Custom signage is designed by our in-house graphic artist. Provide your logo/ branding in high resolution VECTOR FORMAT (.ai, .eps or vector PDF) and we'll do the rest! A proof will be provided for review prior to print production.



INCLUDES UPGRADES WORTH OVER
\$17,000.00!

2 - Solid State Remote Controls - **\$3,450.00 Value**

3 - HD Arkansas Safety Premium Tool Boxes - **\$2,980.00 Value**

1 - Super Duty Hydraulic Powered Hose Reel Upgrade - **\$2,190.00 Value**

1 - Custom Drilled Warthog Nozzle and a Complete Custom Drilled Nozzle Set - **\$1,500.00 Value**

1 - Complete Lateral Cleaning Package Includes Hose Reel, 100' of 1/4" Hose and HD Foot Control - **\$2,495.00 Value**

1 - Complete Power Wash Set-up includes 100' of HD Power Wash Hose - **\$1,780.00 Value**

FREE Attendance to Our Jetter Workshop All Inclusive (flights, meals, rooms, airport transportation) - **\$1,950.00 Value**

Soap Injection System and 1 - FREE CASE of our Premium Drain Line Additive - **\$590.00 Value**

FREE Signage & Artwork for Your New Trailer System - **\$750.00 Value**

HYDRAULIC SYSTEM:

- » Belt Driven
- » Large Reservoir To Keep The System Cool
- » Large Filter System
- » Easy To Run Hydraulic Controls



REMOTE CONTROLS:

- » Solid State
- » Best in the Business!