

BUILT FOR THE PRO!



KUBOTA DIESEL COLD WATER JETTER



- Full Hydraulic Hose Reel**
Equipped with either 300' 3/8" or 300' 1/2" or 500' of 3/8", our full hydraulic hose reels feature a roller guide arm that helps preserve the longevity of the reel.
- Pump**
The pump systems we use are manufactured by Industrial Division of Giant Pumps. These Premium Tri-Plex Pumps are proven with literally thousands in service worldwide. They are easy and inexpensive for service.
- Pump Saver System / EZ Start Valve**
We engineer all jetter trailers with our "pump saver system" - that when the hose flow is released, the bypass water re-circulates back to the water tank. This keeps the head of the pump cool extending its life substantially.
- TBDS™ (Total Belt Driven System)**
All components are belt driven. The pump is Triple-V-Belt Driven. Belt driven reduces vibration and allows the pump to run at 1/2 RPM. This extends operational life, especially vs. gear driven power plants.
- Detergent Application / Injection**
The equipment operator can control the concentration levels at the machine and controls the detergent injections depending on the job needs.
- Quick Antifreeze System / Recycle System**
Our jetter units come with our quick antifreeze system where you close one ball valve and open the antifreeze ball valve - then run the machine for 30 seconds and the entire system is antifreezed. Start the machine - then recapture the antifreeze in the antifreeze tank and re-attach the jetter nozzle and you are ready to jet!

Model Number: XFDTA1240KK

FEATURES:

- 24.8HP Kubota Diesel Engine Tier 4
- 12GPM @ 4,000 PSI
- Drive Triple V-Belt
- Trailer Size 5' x 12' Deck
- Tandem Axle, Powder Coated
- Axle Rating 2 x 3,500 LB.

1.800.624.8186
www.HotJetUSA.com

08-20-2024

KUBOTA DIESEL 24.8HP ENGINE

MODEL		D1305-E48
EMISSION REGULATION		Tier 4
TYPE		Vertical 4-cycle Liquid Cooled Diesel
NUMBER OF CYLINDERS		3
BORE	MM (IN)	78.0 (3.07)
STROKE	MM (IN)	88.0 (3.46)
DISPLACEMENT	L (CU. IN)	1.261 (76.95)
COMBUSTION SYSTEM		IDI
INTAKE SYSTEM		Naturally Aspirated
MAXIMUM SPEED	RPM	2600
OUTPUT: GROSS INTERMITTENT	kW	18.5
	HP	24.8
	PS	25.2
DIRECTION OF ROTATION		Counterclockwise Viewed on Flywheel
OIL PAN CAPACITY	L (GAL)	5.7 (1.51)
STARTER CAPACITY	V-KW	12-1.2
ALTERNATOR CAPACITY	V-A	12-40
LENGTH	MM (IN)	503.5 (19.82)
WIDTH	MM (IN)	374.4 (14.74)
HEIGHT (1)	MM (IN)	590.1 (23.20)
HEIGHT (2)	MM (IN)	215.6 (8.49)
DRY WEIGHT	KG (LB)	95.0 (209.4)

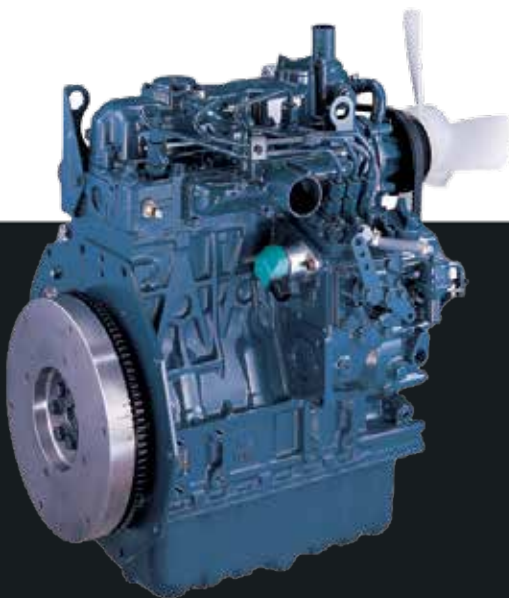
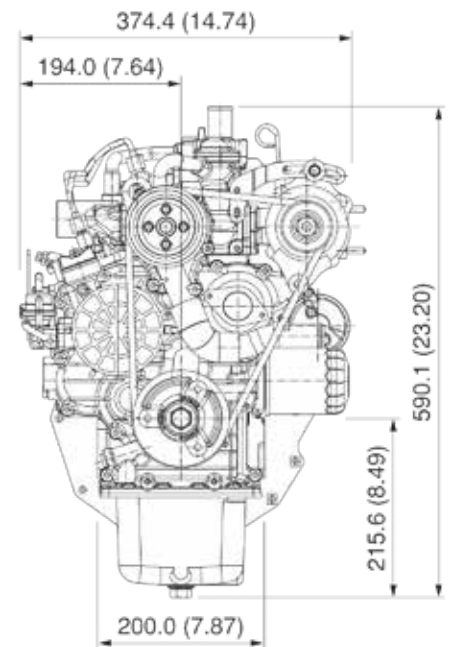
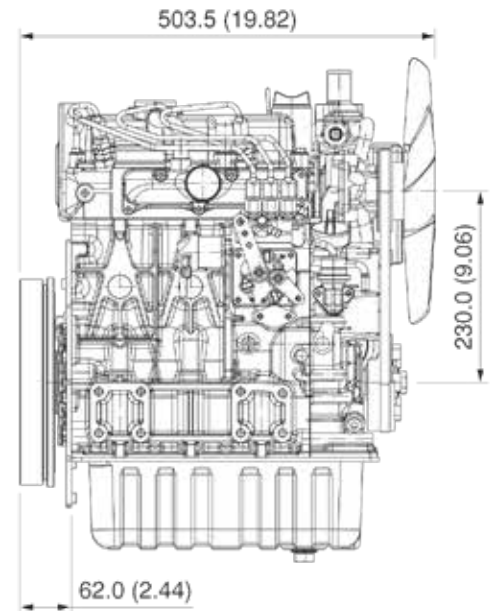

The D1305 engine complies with EPA Tier 4 emissions regulations which is the most stringent emissions regulations in the world in this class.

Kubota engine less than 19kW meets emission standards over the NRTC and also meets the NTE requirements.

GIANT PUMP P400HP SERIES

Operation and Maintenance

Check oil level prior to starting to ensure trouble-free water supply.

Important!

If there is a danger of frost, the water in the pump and in the pump fittings (particularly the unloader valve) must be emptied. The second discharge port can also be used and the pump run "dry" for 1-2 minutes for this purpose.

Oil amount: 30.4 ounces (0.9 liters). Only use ISO VG 220 industrial gear oil (e.g. Aral Degol BG220) or automobile gear oil SAE 90 GL4 (Giant p/n 01154).

Initial oil change after 50 operating hours and then every 500 hours, after 1 year if used less. Caution when operating in damp places or with high temperature fluctuations.

Oil must be changed immediately should condensate (frothy oil) occur in the gear box.

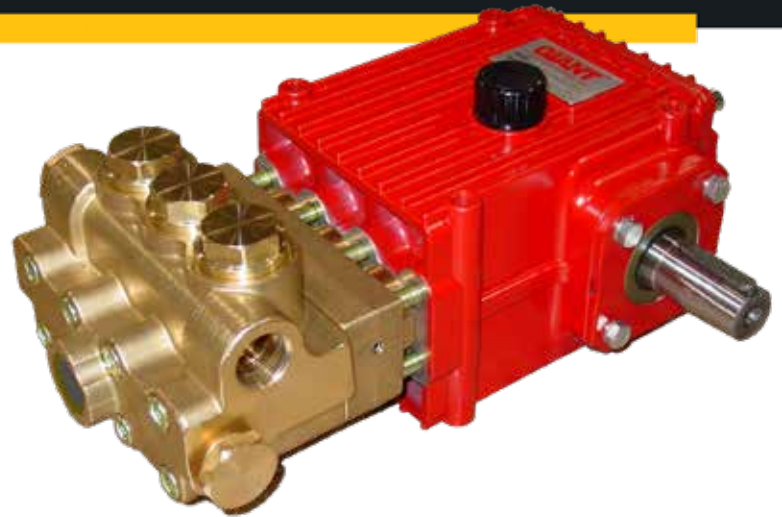

NPSH values must be observed.

Maximum input pressure 145 PSI (10 bar), maximum suction head -4.35 PSI (-0.3 bar). Make sure that suction pulsation is sufficiently dampened - water column resonance must be avoided.

Important!

If the pump is not used for a long period of time, it is possible the seals (23/23B) could become hard or brittle thus causing the pump to leak when put into operation. If this is the case, we recommend these seals be replaced every 4 years.

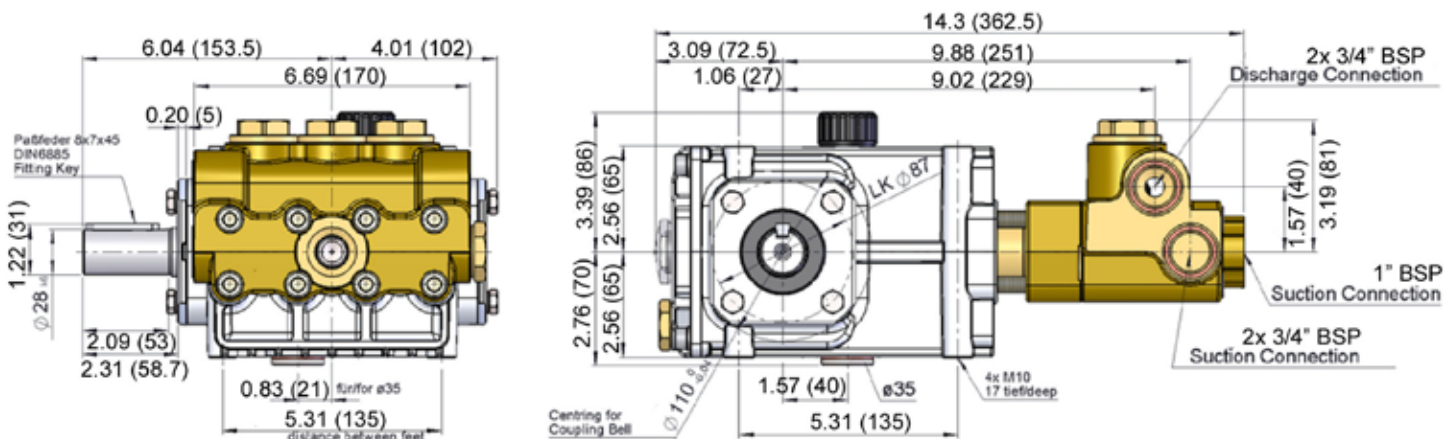

COLD WATER DIESEL SERIES SPECIFICATIONS

GENERAL SPECIFICATIONS

- 330 or 660 Gallon Water Capacity
- Molded HDP Water Tank(s)
- Nema 4 Rated Control Panel
- Low Water "Shut Off" Feature
- 10' Safety Colored Leader Hose
- 2" x 36" Tiger Tail Hose Protector
- Powered, Variable Speed Hose Reel with 300' of 3/8" Jetting Hose Rated @ 16,000 PSI Burst Pressure
- Adjustable Pressure Relief/Control Valve(s)
- Adjustable Pulsation System with Control
- Hose Reel with 100' of 3/4" Supply hose
- Rotary Beacon Light
- "Fast Fill" for Hydrant Hook-Up

PUMP

- "Run-Dry" Capable Tri-Plex Pump
- 12 GPM @ 4,000 PSI (+/- 5%)
- Triple Power Belt Driven
- Dual Safety Relief Valves and Pump Saver System
- Rear Throttle Control

MOTOR DESCRIPTION

- 24.8HP Kubota
- Low Noise Muffler
- EPA Tier 4 Rated
- Low Engine Oil/High Temperature Auto Shutdown System
- 24 Gallon Diesel Fuel Tank
- Large Battery Box
- Extra Large Radiator

TRAILER DESCRIPTION

- Rugged, Compact Specially Engineered Trailer to Haul the Equipment and Water Load
- Leaf Spring Axles Cushion and Distribute the Weight for Easy Towing
- 5'x12' Tandem Axle
- Tandem Axle (2 x 3,500 lb)
- Dual Axle Brake - DOT Legal in all 50 States
- Full Premium Powder Coat
- LED Lighting

NOZZLES

- Warthog
- Lazer, Ram & Spinner

FULL PACKAGE INCLUDES

- Portable Reel with 100' 1/4" Jetting Hose
- Safety Cone Holder
- Rear LED Lighting
- 2 Remote Controls - Solid State Wireless Unit up to 300' Range
- 2nd Hose Reel for Wash Down

OVERALL DIMENSIONS

- Overall Length 16' 6" incl. hitch
- Deck Length 12'
- Height 8' w/safety light
- Overall Deck Width 7'
- Weight Dry 2,950 lbs
- Weight Full Load 6,100 lbs

UPGRADES AVAILABLE

- 14k Trailer w/600 Gallon Water Tank
- Full Hydraulic Control Hose Reel



THE BEST JETTERS DESERVE THE BEST TRAILERS



- » Box Tube Steel Construction
- » Solid Diamond Plate Steel Deck
- » Fully Primed And Powder Coated

BUILT FOR YEARS OF SERVICE



IT ALL STARTS WITH THE TRAILER



TRAILER SPECIFICATIONS

Our HotJet trailers are custom engineered for extreme duty and are the best trailers made - PERIOD!

We are associate members of **NATM - National Association of Trailer Manufacturers** and we manufacture in compliance with their national engineering codes.



FRAME

Our trailers feature a "Rock Solid" 3/16" tube frame (not 1/8") that extends the full length of the trailer. The frame is then welded on the HD C-Channel sub-frame. We directly weld this to our spring support shackles.

TOP DECK

The top deck is full sheathed diamond plate steel decking which adds structural rigidity.

AXLES

We use Dexter brand leaf spring axles. Leaf springs are proven for our applications. They cushion and distribute the weight loads. Each axle has electric brakes.

PAINT / POWDER COAT

We use a premium pre-wash zinc hot-wash. This is followed by a Sherwin Williams primer coat that is exclusively made for powder coating. A Sherwin Williams premium powder coat paint that is engineered to resist corrosion and promote color consistency is then added.

MISCELLANEOUS

We use HD fenders with step plates welded on both sides. The Ram Jack is super duty and rated to lift 8,000 lbs. All lights and markers are LED. Plug is standard 7-way.



CHOOSE YOUR TRAILER COLOR!



Red, Black & Blue Standard Color Options
Custom Paint Colors Available Upon Request - Cost Extra



CUSTOM SIGNAGE AVAILABLE



ARTWORK REQUIREMENTS:

Custom signage is designed by our in-house graphic artist. Provide your logo/ branding in high resolution VECTOR FORMAT (.ai, .eps or vector PDF) and we'll do the rest! A proof will be provided for review prior to print production.

THE BEST JETTERS INCLUDE THE BEST TRAINING CLASSES

